

Cruisair 115/230 volt Stowaway 3-knob W/Start Relay & Start Capacitor Easy Start Wiring

1) **Remove** the 2 purple wires from the start relay (#5) & make a 3-way splice with the Easy Start Black wire.

2) **Remove** the 2 pink wires from the start relay (#2) & make a 3-way splice with the Easy Start Orange wire.

**NOTE:** **Remove** the black wire that goes from the start capacitor to the relay (#1)– Next remove the white/red wire that goes from the start capacitor to the run capacitor.

3) **Remove** the white/red wire from the run capacitor & splice it into the Easy Start Brown wire.

4) Where you just removed the white/red wire from the run capacitor in the previous step, attach the Easy Start White wire.

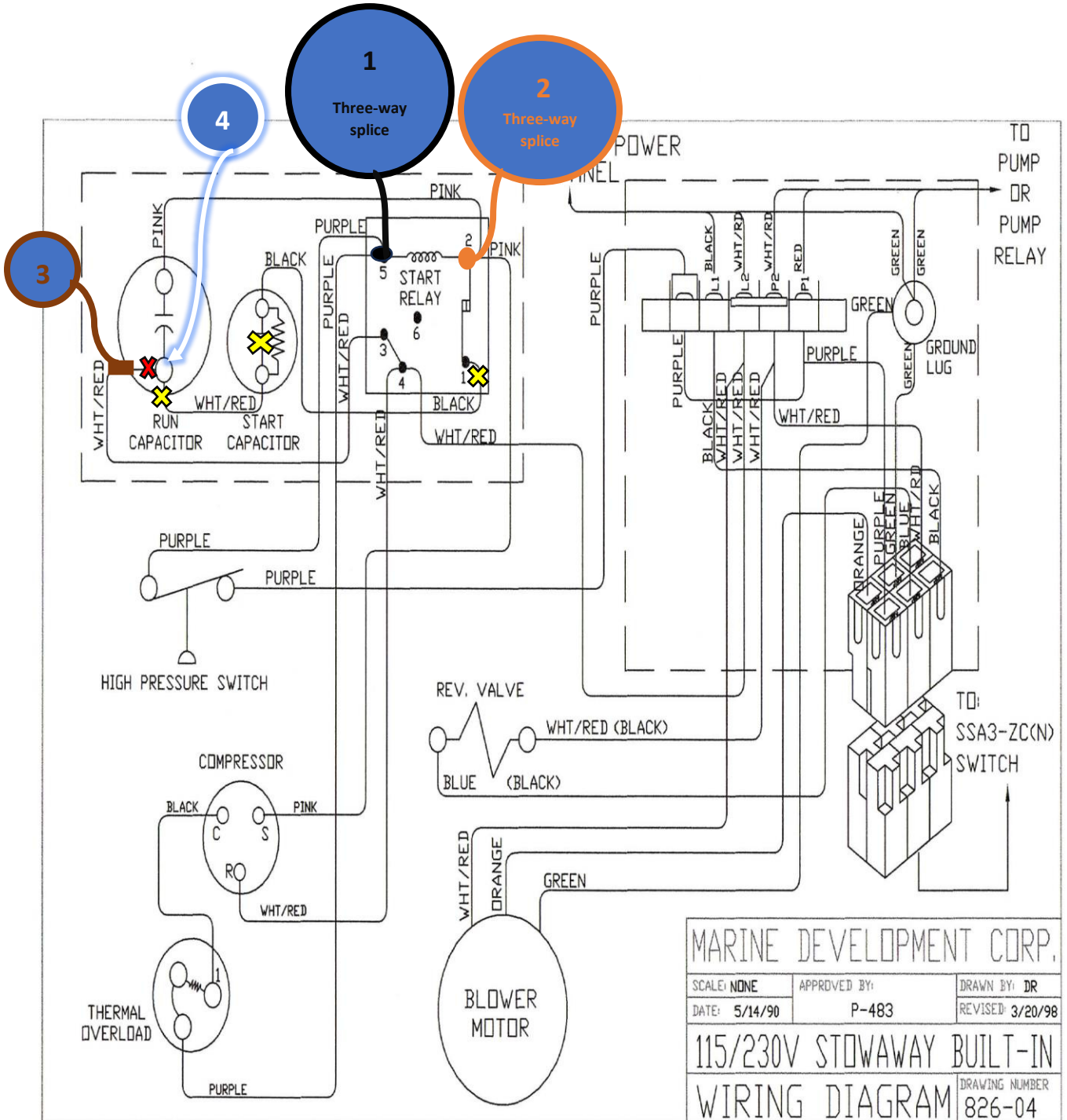

MARINE DEVELOPMENT CORP.		
SCALE: NONE	APPROVED BY:	DRAWN BY: DR
DATE: 5/14/90	P-483	REVISED: 3/20/98
115/230V STOWAWAY BUILT-IN		
WIRING DIAGRAM		DRAWING NUMBER 826-04